

RAVAS

Owner's Manual iCP wireless and cabled

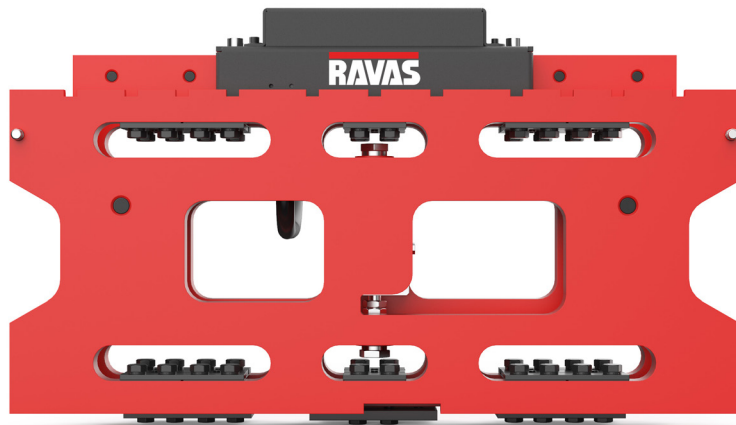

We would like to inform you about the fact that this RAVAS product is 100% recyclable, provided that parts are being processed and disposed of in the right manner.
More information can be found on our website: www.ravas.com

Rev. 20220421
Printing/Typographical errors and model changes reserved.



PLEASE RETAIN THESE INSTRUCTIONS FOR FUTURE REFERENCE

If you have any queries concerning the duration and terms of the RAVAS warranty, please contact your supplier or check our General Sales and Service Conditions, which are available on request.

The manufacturer accepts no liability for any damage or injury caused by failure to follow these instructions, or from negligent operation or assembly, even if this is not expressly stated in this instruction manual.

In light of our policy of continuous improvement, it is possible that details of the product may differ from those described in this manual. For this reason, these instructions should only be considered as guidelines for the installation of the relevant product. This manual has been compiled with all due care, but the manufacturer cannot be held responsible for any consequences of errors. All rights are reserved and no part of this manual may be reproduced in any way.

Table of Contents

1. Introduction	4
2. Warning & Safety measures	4
3. Wireless system - system setup and battery change	5
3.1 Installing the indicator	5
3.2 Placing the battery pack in the iCP	6
3.3 Connecting and switching on the iCP	6
3.4 Switching off the system	7
3.5 Low battery indication iCP	8
3.6 Removing the rechargeable battery pack	8
3.7 Charging the battery pack	9
4. Cabled system - system setup	10
4.1 Installing the indicator	10
4.2 Mast cabling (example)	11
4.3 Indicator power supply from fork lift truck battery	12
4.4 Connecting and switching on the iCP	13
4.5 Switching off the system	13
5. Use	14
5.1 Use (accurate weighing)	14
5.2 Level correction (option)	15

1. Introduction

This manual describes the installation and use of the **iCP**. Read this manual carefully. The installer must be informed of the contents of this manual. Always do things in the correct order. This manual should be kept on a safe and dry place. In case of damage or loss the user may request a new copy of the manual from RAVAS.

2. Warning & Safety measures

When using the **iCP**, please observe the instructions and guidelines contained in this manual carefully. Always perform each step in the right sequence. If any of the instructions is not clear, please contact RAVAS.



- All safety regulations that apply to the truck remain valid and unchanged;
- No weighing operations are allowed if any person or object is in the vicinity; around, under or close to the load;
- RAVAS is not responsible for any physical harm done to the operator as a result of coming into contact with the indicator in the cabin;
- Any modifications done to the system must be approved in writing by the supplier, prior to any work being completed;
- It is the sole responsibility of the purchaser to train their own employees in the proper use and maintenance of this equipment;
- Do not operate this unit unless you have been fully trained in its capabilities;
- Check the accuracy of the scale on a regular basis to prevent faulty readings;
- Only trained and authorized personnel are allowed to service the scale;
- Always follow the operating, maintenance and repair instructions of this truck and ask the supplier when in doubt;
- RAVAS is not responsible for errors that occur due to incorrect weightings or inaccurate scales.

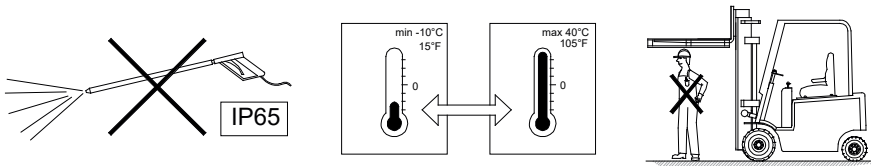

Should you have any further questions after reading this manual then you can contact us at:

RAVAS USA, INC.

1500 Enterprise Pkwy
Twinsbrug, OH, 44087
United States

Phone: +1 (330) 425-3092
Email: salesoffice-usa@ravas.com
Website: www.ravas.com

3. Wireless system - system setup and battery change

3.1 Installing the indicator

Find a suitable position for the indicator:

1. at the cabin's roof.
2. on the right side of the cabin, mounted onto a side-rail.
3. on the dashboard.

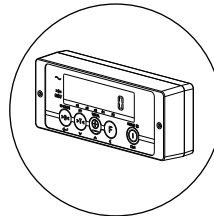
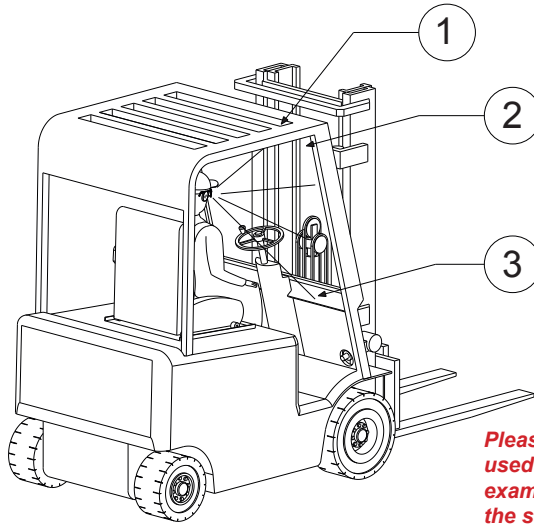

The indicator should be easy to reach and read!

Please note: in this manual we have used images of the 3200 indicator as an example! The functionality of the iCP is the same with any other indicator.

Installation of the indicator bracket and support.

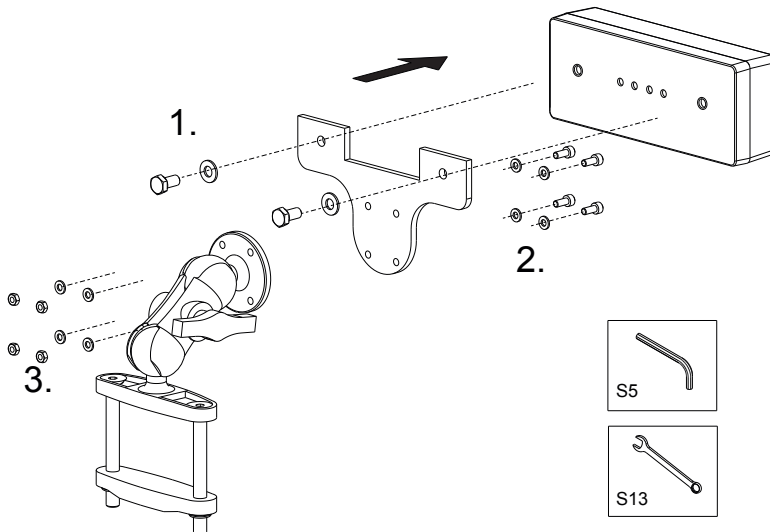

3.2 Placing the battery pack in the iCP

1. Push the red locking clip down to unlock the battery holder of the iCP
2. The battery holder will open automatically.
3. Position the battery pack in the battery holder until the red locking clip shifts up again.
4. Close the battery holder until you hear a "click".

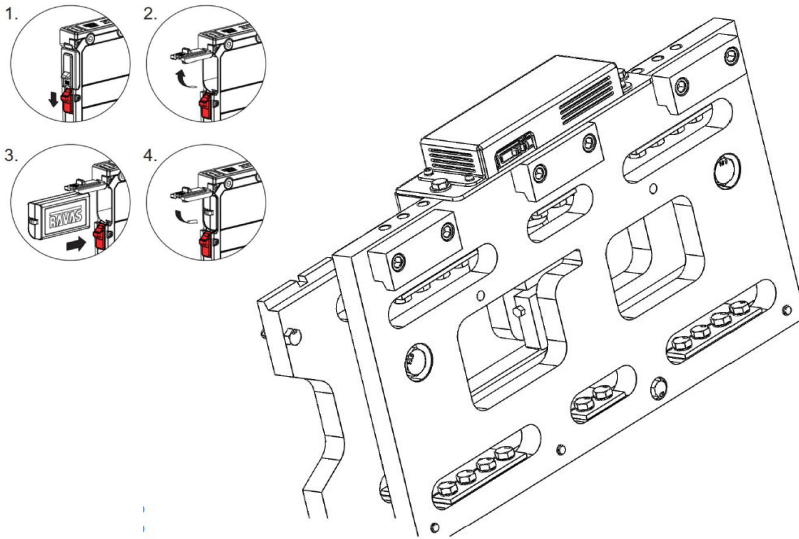

3.3 Connecting and switching on the iCP

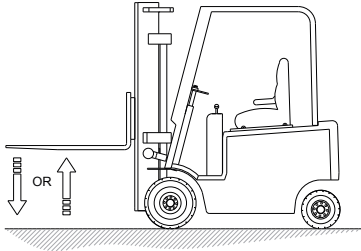
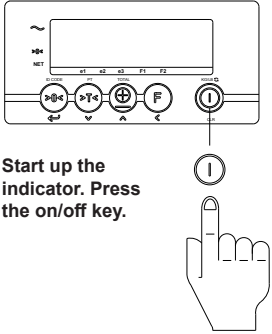
<p>1</p>  <p>Switch on the iCP: Move the iCP quickly in upwards or downwards direction.</p>	<p>2</p>  <p>Start up the indicator. Press the on/off key.</p>
--	--

3

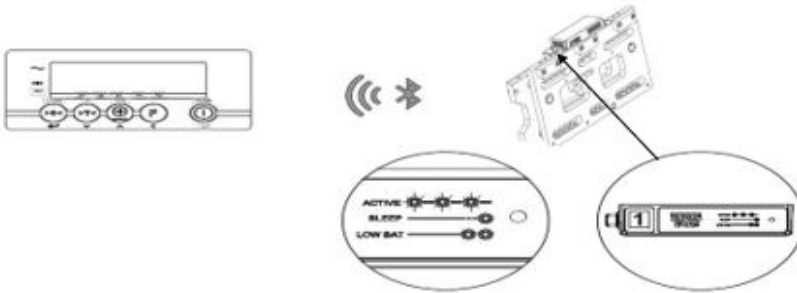

The Bluetooth link between the indicator and the carriage plate will connect automatically.

The iCP is "ACTIVE" when the blue LED on the plate flashes repeatedly.

After 5 seconds all electronics are warmed up and you can start weighing.

3.4 Switching off the system

1

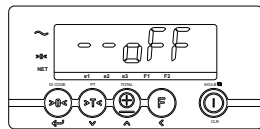

Switch off the indicator by pressing the on/off key for 3 seconds.



2

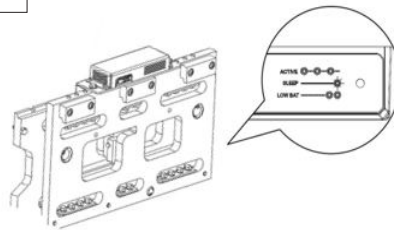

The carriage plate will switch off automatically.

The blue LED "SLEEP" on the carriage plate will start blinking automatically.

3.5 Low battery indication iCP

Exchangeable battery pack supplies power to the iCP.

When the voltage level of the battery pack is running low, the low battery indicator will light up and "F1" will start flickering in the display.

The blue LED on the bluetooth module will start flickering very slowly (twice every 10 sec).

The iCP will switch off automatically after 10 minutes.

FUNCTIONALITY BLUE LED	
DURING POWERING ON	ON for 5 sec.
FULL BATTERY	<i>Flicker time interval</i>
Working mode	Once every 1,5 sec.
Sleep mode	Once every 12 sec.
LOW BATTERY	
Working mode	Twice every 10 sec.
Sleep mode	Twice every 10 sec.

3.6 Removing the rechargeable battery pack

1. Push the red locking clip down to unlock the battery holder of the iCP
2. The battery holder will open automatically.
3. Remove the battery pack from the battery holder.

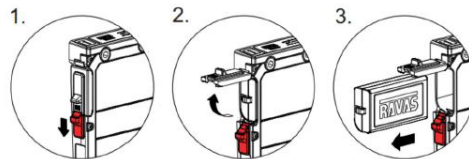

3.7 Charging the rechargeable battery pack

The system is equipped with a rechargeable battery pack and a smart charger. Charge the battery for 8 hours. This will prevent loss of battery capacity.

First position the battery pack inside the charger module, then plug the adaptor into the mains voltage.

Smart charger: When the battery is being charged, the red LED on the charger is lit. After at least 8 hours charging, the charger shuts off and the the battery packs are completely full. The red LED turns off and the green LED will illuminate.

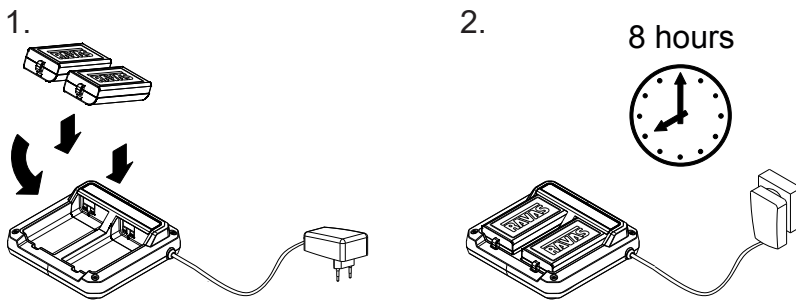

4. Cabled system - system setup

4.1 Installing the indicator

Find a suitable position for the indicator:

1. at the cabin's roof.
2. on the right side of the cabin, mounted onto a side-rail.
3. on the dashboard.

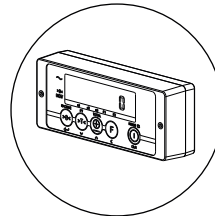
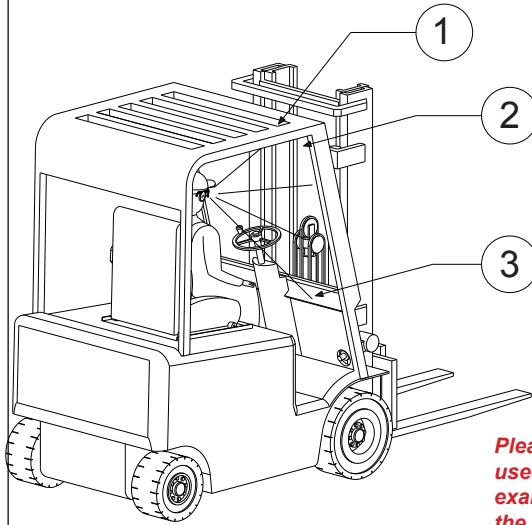

The indicator should be easy to reach and read!

Please note: in this manual we have used images of the 3200 indicator as an example! The functionality of the iCP is the same with any other indicator.

Installation of the indicator bracket and support.

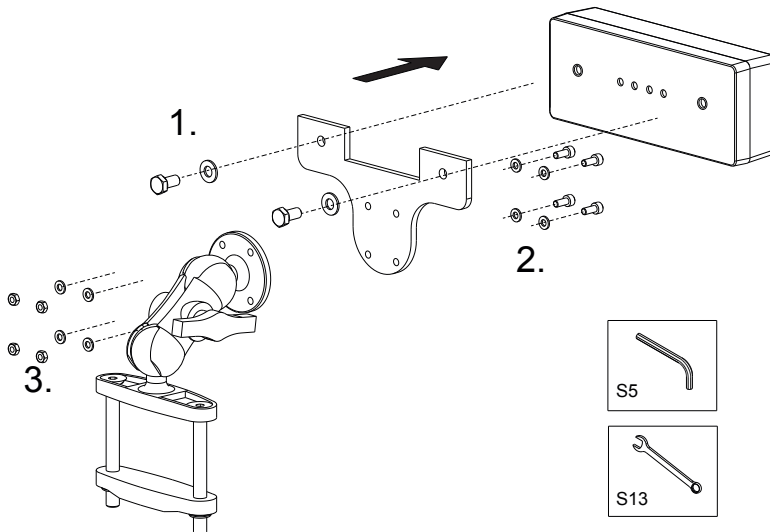

4.2 Mast cabling (example)

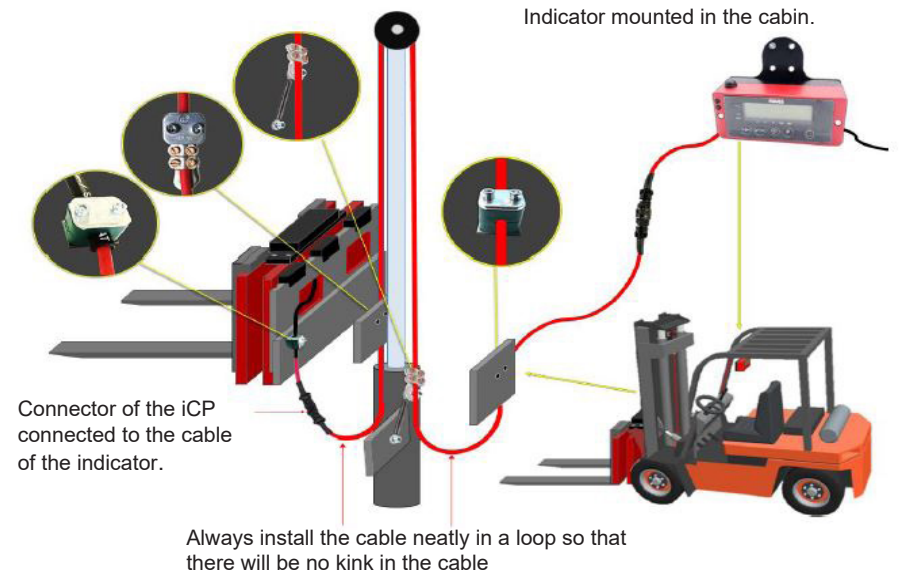

4.3 Indicator power supply from fork lift truck battery

Only possible if indicator is equipped with an integrated voltage converter or voltage stabilizer.

READ LABEL ON BACK FOR POWER SUPPLY INDICATOR
POWER REGULATOR INSIDE + = 12 VDC
POWER CONVERTER INSIDE + = 20-100VDC

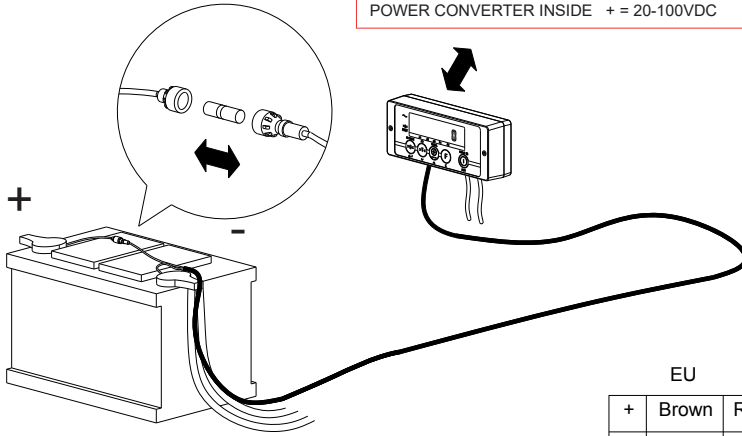

	EU	US
+	Brown	Red
-	Blue	Black

4.4 Connecting and switching on the iCP

1

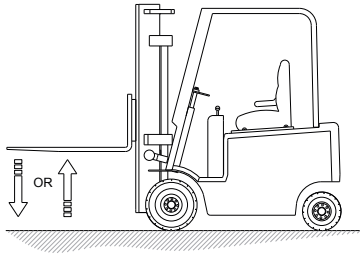

Switch on the iCP:
Move the iCP quickly in upwards or downwards direction.

2

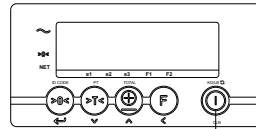

Start up the indicator. Press the on/off key.



After 5 seconds all electronics are warmed up and you can start weighing.

4.5 Switching off the system

1

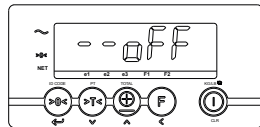

Switch off the indicator by pressing the on/off key for 3 seconds.



5. Use

5.1 Use (accurate weighing)

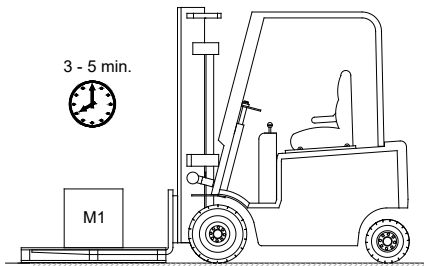

After 3 to 5 minutes the load cells have reached the operational temperature. Don't lift loads before the zero-point correction has been executed.

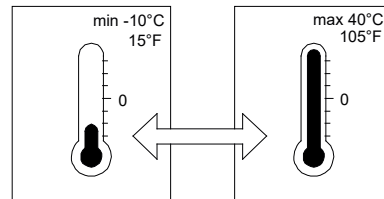
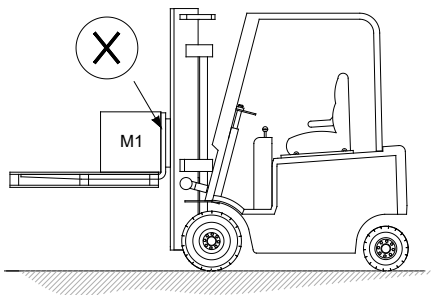
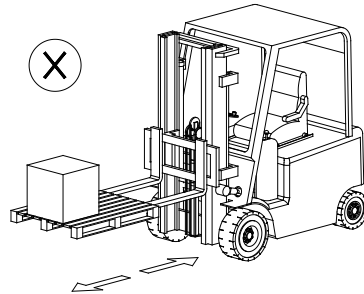
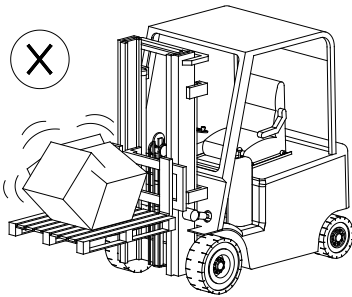
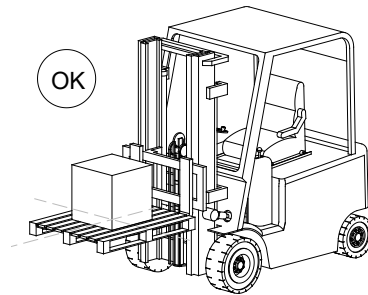

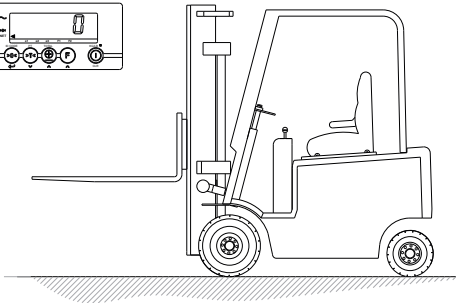
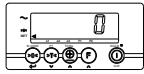

Check the zero reading before each weighing!

Before each weighing it is necessary to check whether the system is unloaded and free.

If the indicator does not determine the zero point automatically, it must be done manually using the >0< key.

5.2 Level correction

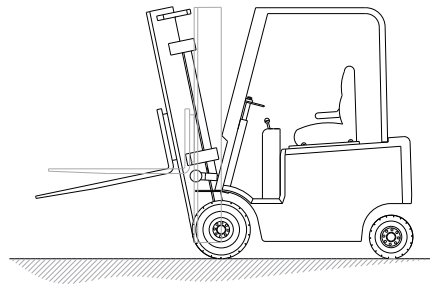
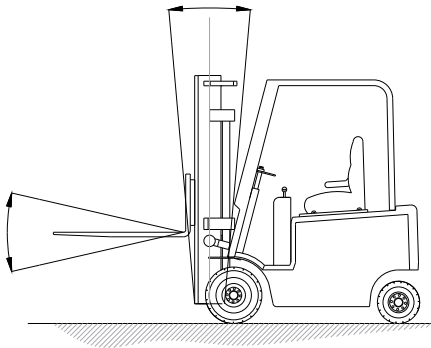

Legal for trade:

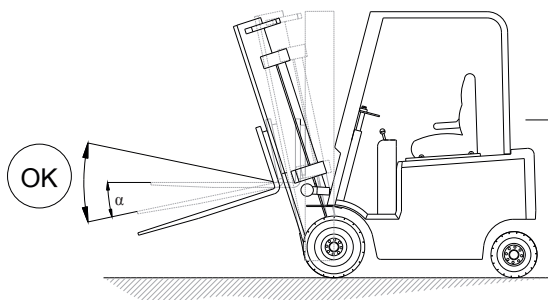

$> \alpha$

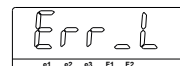

NTEP: OK if $\alpha = \pm 5\%$ (3°)
 OIML: OK if $\alpha = \pm 2^\circ$