

# RAVAS-320

## Hand Pallet Jack

MOBILE  
WEIGHING  
SCALE

Creating additional revenue by re-weighing inbound pallets in your cross docking process is simplified with a RAVAS-320 Hand Pallet Jack. Our mobile weighing system includes a scale and onboard indicator so you can weigh while on the move. Perfect for material handling warehouses and dosing and mixing processes, the RAVAS-320 comes standard with NTEP Legal-for-Trade certification for customers who buy, sell, or charge based upon weight.

### Extended Mobile Weighing Capabilities

- Standard NTEP approved
- High capacity Li-ion battery pack for 75 hours of continuous operation
- Optional automatic dosing function and Bluetooth/WiFi connectivity
- Three communication portals
- Compatible with RAVAS WeightsApp

Effortlessly lift and drive with handle controls

Indicator can be equipped with Bluetooth/WiFi connectivity



Slanted fork tips make it easy to drive into low pallets

# RAVAS-320

## FUNCTIONS

- Automatic and manual zero correction
- Gross/net weighing
- Automatic and manual tare
- Totalling with sequence number
- Code entry (5-digit)
- RS232 port for connection with printer
- Extra port for Bluetooth or WiFi option board
- Bluetooth 4.0 for RAVAS WeightsApp
- Internal clock
- Error messages in display
- Automatic switch-off after 30 minutes of non-use
- lb/kg toggle

## STANDARD SPECIFICATIONS

### WEIGHT CAPACITY

- Max. 5,000 lb

### GRADUATION

- 0 - 5,000 lb: graduation 2 lb  
(optional: multirange graduation)

### MAXIMUM TOLERANCE

- 0.1% of the load lifted

### DISPLAY

- LCD, dual color, digit height 0.79", backlight

### KEYPAD

- 5 function keys, on/of key

### PROTECTION CLASS

- Load cells NEMA 5, display NEMA 4 (printer excluded)

### BATTERY

- 14,8Vdc/5Ah, exchangeable, Li-ionbattery pack, charger included

### BATTERY LIFE

- 75 hours, low battery indication in display

### CHARGER

- 110/120 - 14,8V. Approximately 6 hours charging time

### STEERING WHEELS

- Rubber

### LOADING WHEELS

- Polyurethane, single

### COLOR

- Red (RAL 3000), epoxy painted

### OWN WEIGHT

- 250 lb

### PUMP

- Quick lift

## DIMENSIONS

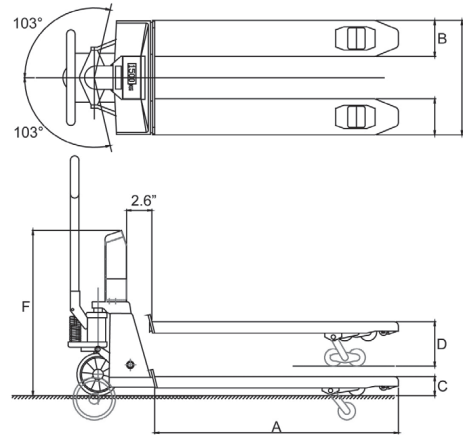

<b>A</b>	Fork length	48"
<b>B</b>	Fork width	7.1"
<b>C</b>	Minimum fork height	3.25"
	Ground clearance	0.7"
<b>D</b>	Maximum fork height	7.9"
	Lifting height	4.8"
<b>E</b>	Width over forks	27.2"
<b>F</b>	Height to top indicator	32.5"

Tolerance +/- 0.1"

## OPTIONS\*

- Extra exchangeable Li-ion battery pack
- Built-in thermal printer
- Bluetooth or WiFi output
- Relay setpoint switch for automatic dosing
- RDC, RAVAS Data Collector Software
- RIS, RAVAS Integration Software
- Stainless steel fork shoes
- Stainless steel truck
- Pivoting indicator; readout from all angles during dosing
- Footbrake
- Different fork dimensions (with different fork height)
- Different steering or loading wheels

\*The use of options may change related specifications.