

RAVAS iJack-26 (2,600 lbs. Capacity)

Electric Pallet Jack

MOBILE
WEIGHING
SCALE

The RAVAS iJack-26 is an electric pallet jack with a built-in scale designed to weigh and lift loads up to 2,600 lbs. Easy to operate and perfect for navigating tight spaces within trailers and warehouse floors, the RAVAS iJack-26 is powered by a lithium-ion battery and comes standard with wireless connection and NTEP (legal for trade) technology. Ideal for retail and commercial environments, the RAVAS iJack-26 is an efficient, high ROI option for replacing your hand pallet jack or floor scale.

A Compact, Powerful Electric Pallet Jack

- Built-in scale and WiFi-enabled onboard indicator are standard
- Powered by a rechargeable lithium-ion battery
- Ergonomic handle with reversing switch, horn, and intuitive dual thumb controls for safe and accurate operation
- Compact body easily navigates tight corners
- NTEP (Legal for Trade) certified



RAVAS iJack-26

DRIVE AND TRAVEL CONTROLS

- 48-Volt Curtis Travel Control with permanent magnet drive motor
- Variable speed from 0 MPH to 3.4 MPH empty
- Variable speed from 0 MPH to 3.1 MPH loaded

STANDARD SPECIFICATIONS

WEIGHT

- 288 lbs. with Battery

TIRES

- Drive (1) 8.3" X 2.8" Polyurethane
- Load (2) 2.4" X 3.1" Polyurethane

FORKS

- 27" OAW X 46" OAL Standard
- Maximum Elevation of 7.5"

CONTROL HEAD

- Travel, lift & lower functions, and creep speed controls
- Easy Operation for Either Hand
- Belly Button Reversing Switch, Dural Butterfly Travel Controls, Wake-Up Buttons, and Key Switch
- Low Mounted Tiller Arm for Comfort and Minimum Steering Effort

HYDRAULICS

- DC Pump and Chrome Plated Cylinder

ELECTRICAL

- Water Resistant Connectors & Wired Harness Supply Power Reliably to Components
- Emergency Power Disconnect
- Covered On-Board Dock for Easy Exchange

BRAKES

- Electromagnetic Brakes

SERVICEABILITY

- Removable Covers & Modular Design of Components
- Two Piece Drive Wheel
- Easy Exchange HD Battery Delivers up to 3.0 Hours of Operation & Charged within 1.5 Hours
- Temperature range 32°-104°F

DIMENSIONS

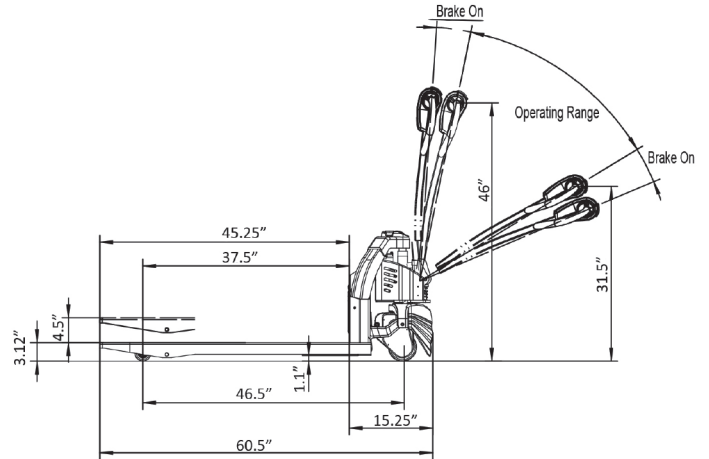

Fork length	45.25"
Fork width	5.9"
Width over fork	27"
Lowered fork height	3.54"
Ground clearance	1.1"
Lifting height	4.5"
Total truck length	60.5"
Truck width	27"
Truck height	46"

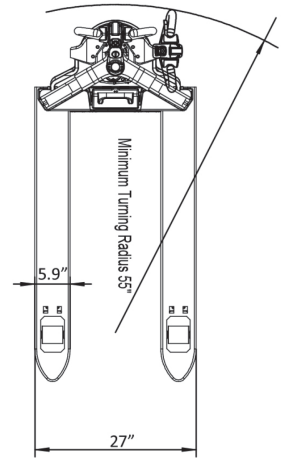

RAVAS INDICATOR APP

- RAVAS Indicator App for data capture on tablets and smart phones

