

iJack-40 (4,000 lbs. Capacity)

Electric Pallet Jack

**MOBILE
WEIGHING
SCALE**

When your job is to move, weigh, and track materials as they travel through a warehouse, every second counts. Eliminating steps in your handling process can improve operational efficiencies that will add up to higher profits. The iJack, a mobile weighing electric pallet jack, lifts, weighs, stores, and shares data in seconds. The iJack delivers results you can count on by eliminating redundancies and ensuring accuracy.

Move Forward with the iJack

- Built-in scale and WiFi-enabled onboard indicator are standard
- Powered by a rechargeable lithium-ion battery
- Ergonomic design improves productivity and safety
- Compact body easily navigates tight corners
- NTEP (Legal for Trade) certified



iJack-40

DRIVE AND TRAVEL CONTROLS

- 48-Volt Curtis Travel Control with permanent magnet drive motor
- Variable speed from 0 MPH to 3.4 MPH empty
- Variable speed from 0 MPH to 3.1 MPH loaded

STANDARD SPECIFICATIONS

WEIGHT

- 390 lbs. with Battery

TIRES

- Drive (1) 8.3" X 2.8" Polyurethane
- Load (2) 2.9" X 3.5" Polyurethane

FORKS

- 27" OAW X 46" OAL Standard
- Designed for Standard Forks 42" & 48" Pallets and Other Common Skids and Containers
- Maximum Elevation of 7.75"

CONTROL HEAD

- Travel, lift & lower functions, and creep speed controls
- Easy Operation for Either Hand
- Belly Button Reversing Switch, Dural Butterfly Travel Controls, Wake-Up Buttons, and Key Switch
- Low Mounted Tiller Arm for Comfort and Minimum Steering Effort

HYDRAULICS

- DC Pump and Chrome Plated Cylinder

ELECTRICAL

- Water Resistant Connectors & Wired Harness Supply Power Reliably to Components
- Emergency Power Disconnect
- Covered On-Board Dock for Easy Exchange

BRAKES

- Electromagnetic Brakes

SERVICEABILITY

- Removable Covers & Modular Design of Components
- Two Piece Drive Wheel
- Easy Exchange HD Battery Delivers up to 3.0 Hours of Operation & Charged within 1.5 Hours
- Additional Set of Li-ion Battery Pack
- Temperature range 32°-104°F

DIMENSIONS

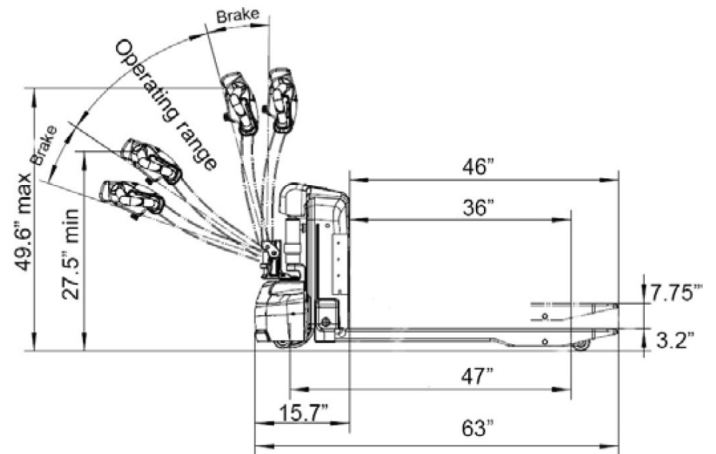

Fork length	46"
Fork width	6"
Width over fork	27"
Lowered fork height	3.54"
Ground clearance	1.2"
Lifting height	7.75"
Total truck length	63"
Truck width	27"
Truck height	49.6"

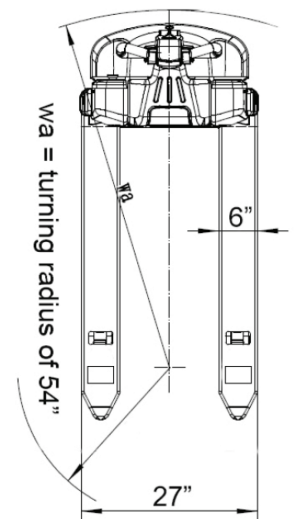

RAVAS WeightsApp

Connect with your RAVAS Weighing System

- RAVAS WeightsApp for data capture on tablets and smart phones

