

# RAVAS iCP WiM-2500

Weigh in Motion

MOBILE  
WEIGHING  
SYSTEM

## RAVAS iCP Weigh in Motion (WiM)

**Weigh while driving - also available in legal for trade**

Discover the future of weighing with our intelligent carriage plate (iCP) and Weigh in Motion technology! Our advanced systems provide accurate and reliable weight determination while your fork lift truck is in motion. Increase efficiency, reduce costs and minimize unnecessary transport movements and manual handling. With our seamless integration into your TMS, WMS or ERP systems, we provide real-time weight control, load optimization and prevention of truck over- or underloading. Benefit from instant billing with data from our legal for trade version.

**Make your operations smarter, safer and more sustainable with our technologies!**

## BENEFITS

- Weighing while driving
- Save time and avoid unnecessary process steps
- Robust forklift scale, for heavy duty applications
- Total width of front plate available for weighing
- Cabled connection between indicator and iCP
- Also weighs in combination with fork spreader attachments
- Ideal in combination with volume measuring systems

Top quality  
For logistics use

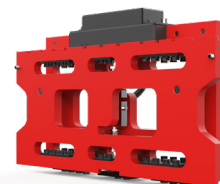
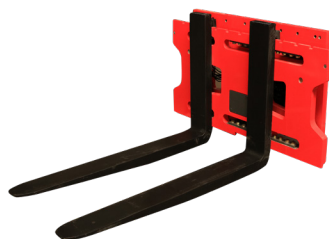
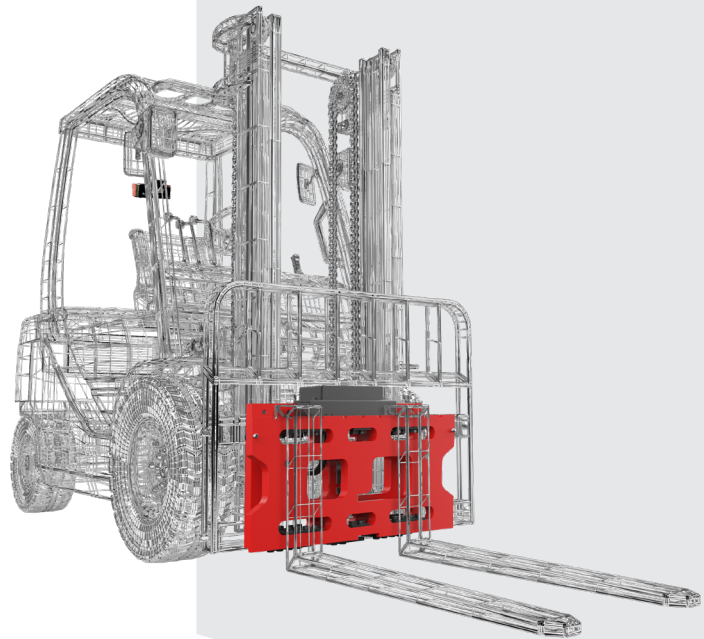

# RAVAS iCP WiM-2500

## FUNCTIONS

- Automatic and manual zero correction
- Gross weighing
- Integrated tilt sensor
- Internal clock for date and time
- Wireless output for data communication between indicator and external device that works with WiFi or Bluetooth® technology
- Overload protection 200% on mechanical construction

## STANDARD SPECIFICATIONS

- Weighing capacity 2,500 kg
- Graduation 2 - 5 kg
- System tolerance 0.2 - 0.4 % of load lifted
- Max. driving speed 12 km/h\*
- Overload protection 200%
- Protection class IP65 / NEMA 4
- Power supply (cabled) from truck battery, via power convertor / regulator
- Signal transmission RS232
- Converter 9-100Vdc - 12Vdc

\* Speed and measurement time may vary based on driving surface, driving style and mass of load

## OPTIONS

- Legal for trade version
- RIS - RAVAS Integration Software
- RAVAS Indicator App

## DIMENSIONS IN MM

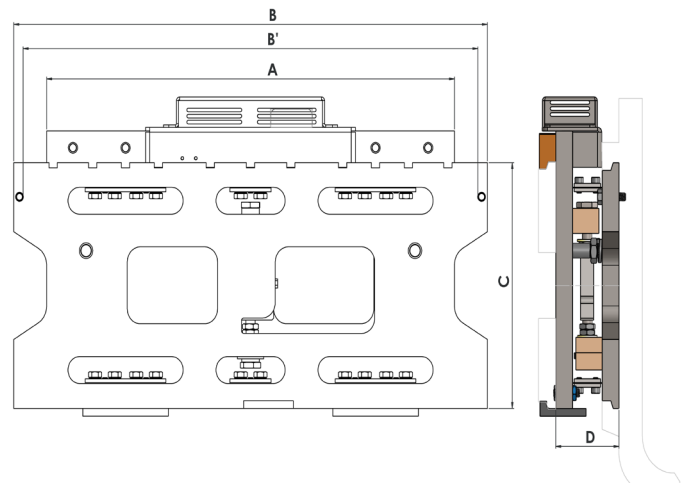

iCP 2500 FEM II

A	Width back plate	788
B	Width front plate	915
B'	Free space between bolts	880
C	Height carriage plate	407
D	Thickness carriage plate	121
Hcg	Horizontal centre of gravity	61
Vcg	Vertical centre of gravity	229
	Own weight (kg) based on std. dimensions	159

Tolerance +/- 2 mm according ISO 2328

**Note:** The fork lift truck dealer must use the above data to recalculate the lifting capacity. In addition, according to directive 2006/42/EG the fork lift truck dealer must adjust the ID plate on the fork lift with revised information about lifting capacity and load center.

