

RAVAS RWB

Weighing Beam

MOBILE
WEIGHING
SYSTEM

The RAVAS RWB (model **RWB ND**) is a U-shaped, removable weighing beam. It has an extremely solid construction which is practically undestructable. Despite its solid looks, the beam is lightweight and easy to move.

The weighing system has a high accuracy with a maximum error of 0,1% of the applied weight. In addition to the standard dimensions, other dimensions are offered on demand.

RAVAS INDICATORS

The RAVAS RWB can be delivered with various types of RAVAS indicators. Each indicator has its own specific functions and can be used in various applications. The RAVAS indicators have been developed especially for mobile applications. Therefore they have a robust construction and are resistant to shocks and vibrations. RAVAS indicators are compact, due to the use of SMD techniques. All indicators are dust and waterproof according to norm IP65, thus enabling use in the open.

Available with different type of indicators, both cabled and wireless

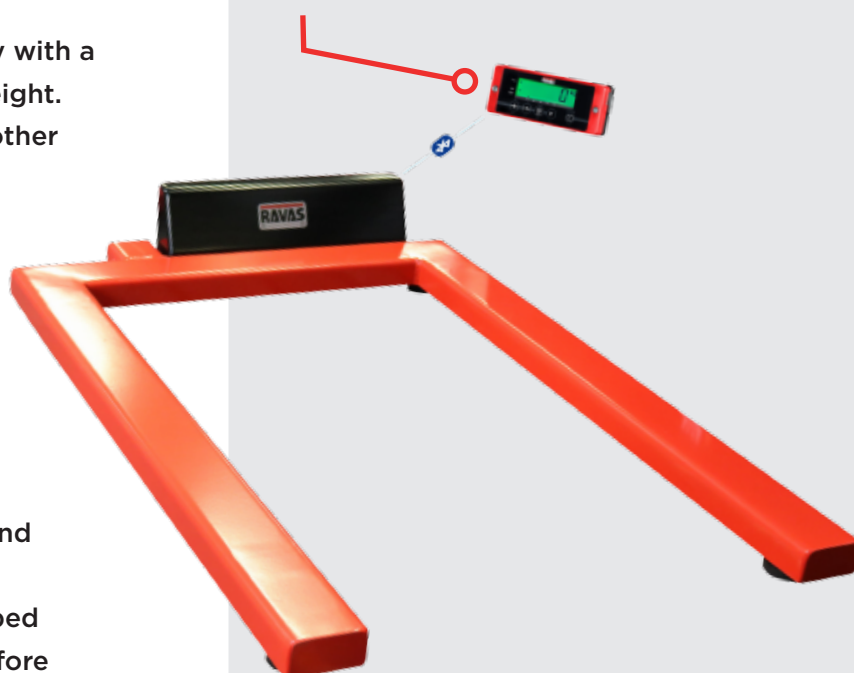

Standard dimensions
and on demand

STANDARD SPECIFICATIONS

- Weighing capacity 2.000 kg
- Multirange 0,2 / 0,5 / 1 kg
- Maximum error 0.1% of the applied weight
- Load cells overload capacity with 50 %
- Functionality determined by indicator (see relevant specification sheet)
- Weight: 35 kg
- Indicator on wall bracket
- Protection indicator IP65
- Protection load cells and cabling IP67
- Cables and connectors protected
- Equipped with rubber support
- Power supply: 230 V
- Colour: red (RAL 3000)

OPTIONS WEIGHING SYSTEM

- Smaller graduations for a more precise indication (with a reduced capacity).
- Approved version OIML class III, certificate T2938
- Explosion proof version for zone I; ATEX certified
- Thermal or matrix printer in separate enclosure
- Data transfer via Bluetooth or with data card system for storage of weighing data

OPTIONS WEIGHING BEAMS

- A disassembled version to be used as two separate weighing beams (model **RWB DE****)
- Tripod
- Capacity 4.000 kg
- Enforced plate, for upgrade to platform
- Stainless steel version

DIMENSIONS

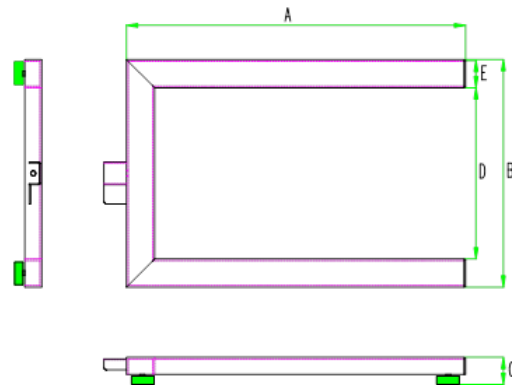

STANDARD DIMENSIONS IN MM*

A	Length	: 1200
B	Width	: 810
C	Height	: 70
D	Between beams	: 610
E	Width beam	: 100

* Other dimensions are on demand.



** The **RWB DE** model with tripod