

RAVAS 256X

Hand Pallet Jack

MOBILE
WEIGHING
SYSTEMS

Working in extreme conditions can pose risks to both personnel and equipment. The RAVAS 256X was specifically designed to operate in environments that may be volatile. This mobile weighing system is explosion proof and conforms to the highest standards for safety and property loss prevention.

Designed for Hazardous Environments

- Safely weigh while on the move in hazardous areas
- FM approved for USA and Canada
 - Class I,II,III Division 1, Groups A-G,
 - Temperature class T4, Ta = 104 F
- Stainless steel fork cover
- Perfect for mixing and batching
- Rotating display, visible from all sides
- Rechargeable and exchangeable battery
- Large, 6-digit LED display



RAVAS 256X

FUNCTIONS

- On/off key
- Numeric keypad with large digits
- Automatic and manual zero correction
- Automatic tare by push button
- Automatic switch-off after 30 minutes of non-use
- 10x higher display resolution
- lb/kg toggle

DIMENSIONS

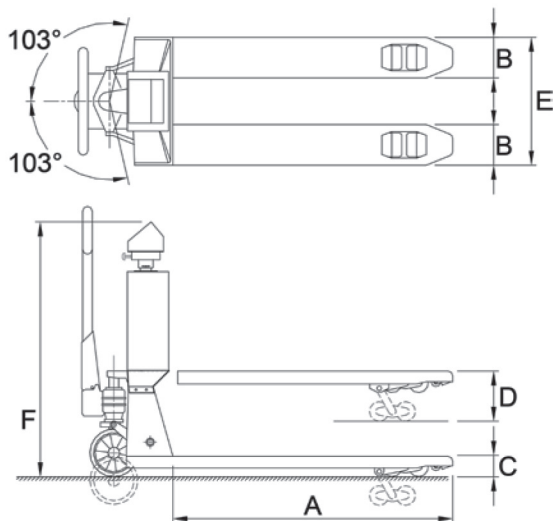

A	Fork Length	47.5"
B	Fork Width	6.7"
C	Minimum Fork Height	3.35"
D	Maximum Fork Height	8"
	Lifting Height	4.75"
E	Width Over Forks	27"
F	Height to Top Indicator	43"

STANDARD SPECIFICATIONS

CAPACITY

- 5,000 lb.

GRADUATION

- 1 lb.

MAXIMUM TOLERANCE

- 0.1% of the load lifted

DISPLAY

- backlit LCD, 1.2" high digits

PROTECTION CLASS

- System IP65, load cells and terminal IP67

BATTERY CYCLE TIME

- 70 hours

CHARGING TIME

- Approximately 6 hours

STEERING WHEELS

- Rubber, antistatic

LOADING WHEELS

- Polyurethane, single

OWN WEIGHT

- 330 lbs.

FINISHING/COLOR

- Epoxy coated / red, RAL3000

FM CERTIFICATION

- Class I,II,III Division 1, Groups A-G, Temperature class T4, Ta = 104 F